

## Dough Mixers

### 10 liter Liquid Spiral Dough Kneader, 2 Speed

ITEM # \_\_\_\_\_

MODEL # \_\_\_\_\_

NAME # \_\_\_\_\_

SIS # \_\_\_\_\_

AIA # \_\_\_\_\_



601256 (PSF50)

Liquid Spiral Dough  
Kneader, 10 liter, 2 Speed -  
400-440V/3/50-60

### Short Form Specification

Item No. \_\_\_\_\_

For kneading special breads, Viennese pastries and pizza dough. Constructed in painted steel. 10 litre liquid capacity; 50 litre stainless steel bowl. 2 speeds. Bowl positioned in the front of the machine making the dough easier to remove once kneaded. Stainless steel spiral cylindrical bar tool equipped with a system to prevent the dough from raising up. The bottom of the bowl is raised in the centre keeping the dough in the area where the tool operates. Safety device to stop the machine if the cover is opened. Control panel incorporates an on/off switch and timer. IP55 protection for electrical controls.

### Main Features

- 50 liter bowl capacity, suitable for kneading special breads, viennese pastries and pizza dough.
- Suitable for free-standing installations.
- Transparent protective screen to reduce flour dust release in the work area during slow kneading.
- Bowl positioned in front of the machine to facilitate dough removal.
- Bottom of the bowl to be raised in the center to keep the dough around the kneading area.
- Control panel with on/off switch and timer.
- Safety device stops the machine when the cover is opened.
- Maximum working capacity of 10 liter (liquids), i.e. 26 kg of dough per cycle, depending on hydration rate.

### Construction

- 10 liter liquid capacity.
- IP55 protected
- Stainless steel bowl and spiral tool with system preventing dough rising.
- Two speed kneading motor (100 and 200 rpm) for a faster kneading process.

APPROVAL: \_\_\_\_\_

Front

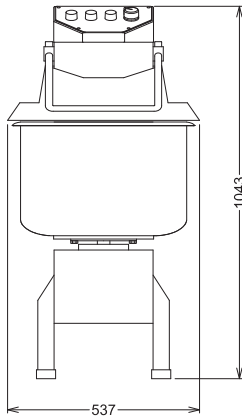

**Electric**

<b>Supply voltage:</b>	
601256 (PSF50)	380-440 V/3 ph/50/60 Hz
<b>Total Watts:</b>	2 kW

**Key Information:**

<b>Bowl capacity:</b>	50 lt
<b>External dimensions, Width:</b>	537 mm
<b>External dimensions, Depth:</b>	968 mm
<b>External dimensions, Height:</b>	1043 mm
<b>Shipping weight:</b>	179 kg

Side

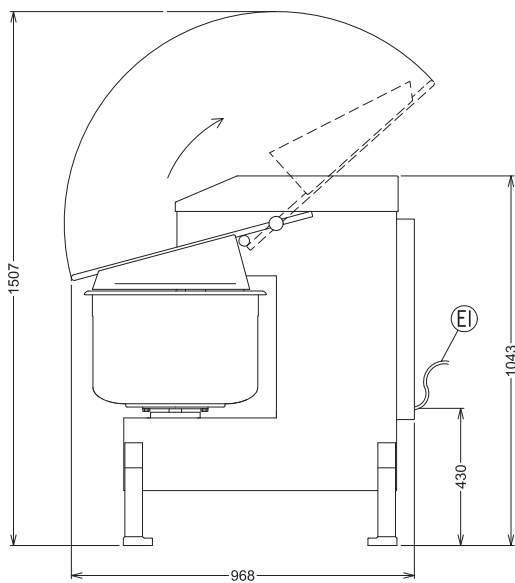

EI = Electrical inlet (power)

Top

